

A brief:

# Electrical Technician Basics

Some  
Safety

Mostly  
Practical  
Use

How to be useful, but not dangerous?

# Instructor

- **Name: Ryan Bates**

**Job:** hardware engineer/ teacher

- **Fun Fact: Can build things**

# CONTENTS

- 01. Welcome + Goals, “Where am I?”
- 02. Units + Electric Flow, Ohm’s Law
- 03. Multimeter Use
- 04. DC Power Supply
- 05. Kill-a-watt and AC
- 06. Residential Circuits
- 07. “E-bike” circuit
- 08. ??

# CONTENTS (learn from experience)

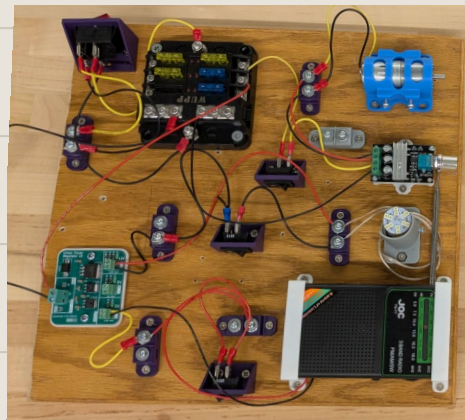
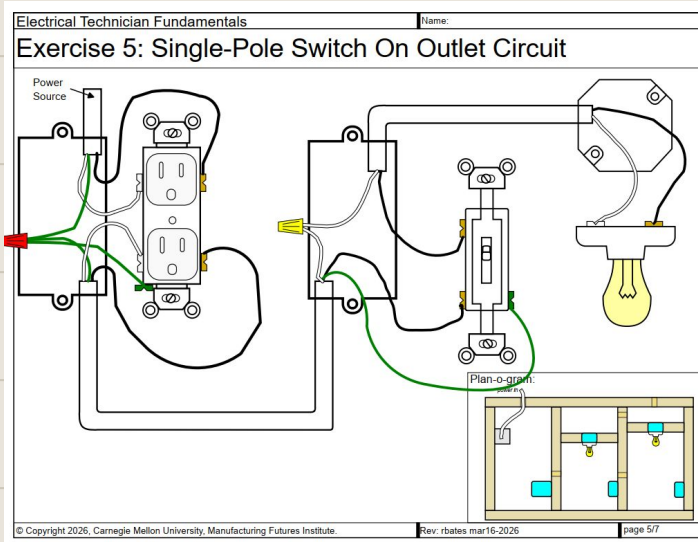
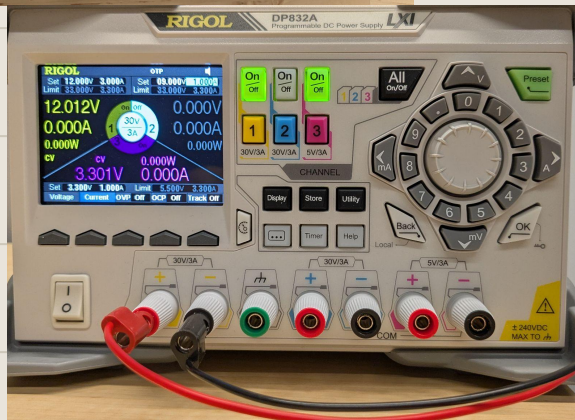

## A lot of information

Electrical work is a lifelong learning trade.

We are just getting a taste. There is a lot to learn, it cannot be done in a day.

- ! Don't make assumptions.
- ! Understand the safety risks.
- ! If you are unsure, don't.



# Electric Flow (is like water)

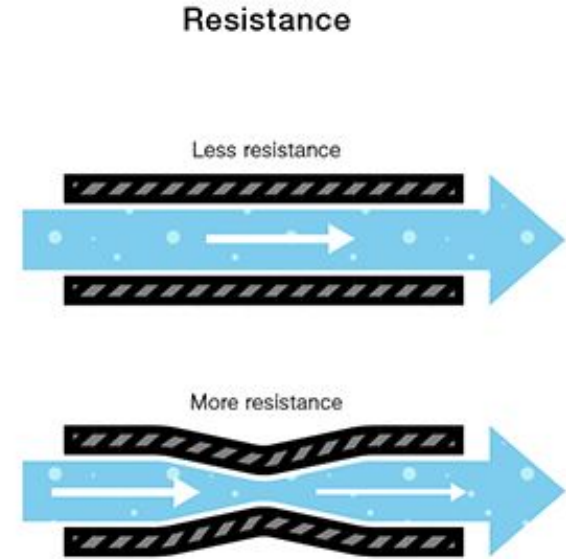
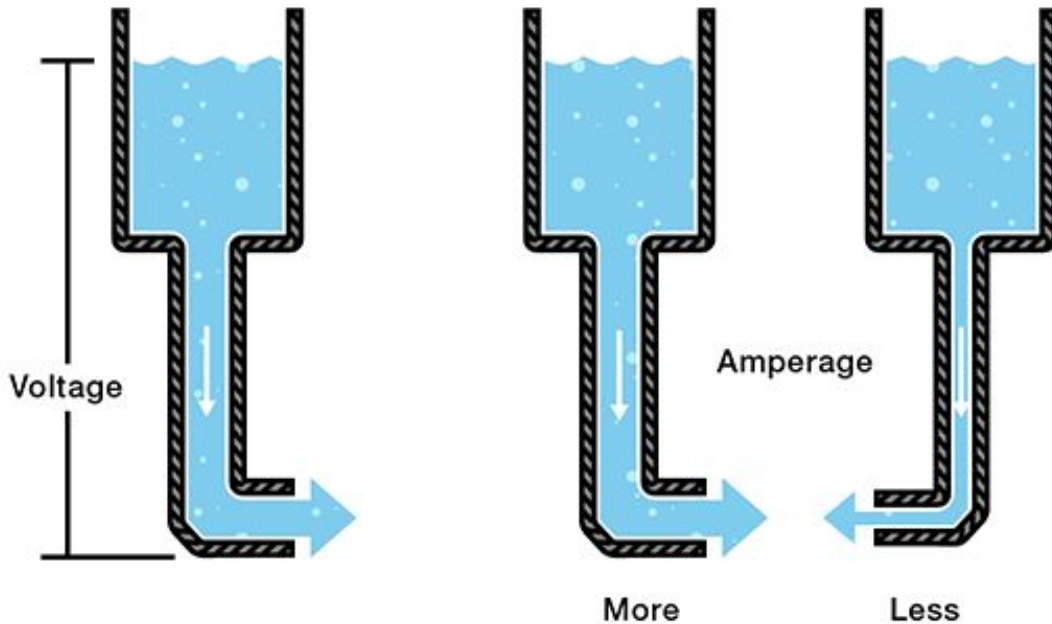

(v) Voltage = Push

(I) Amperage  
(current) = Flow

(R) Resistance =  
resistance (duh)

# Safety

Current kills, not voltage.

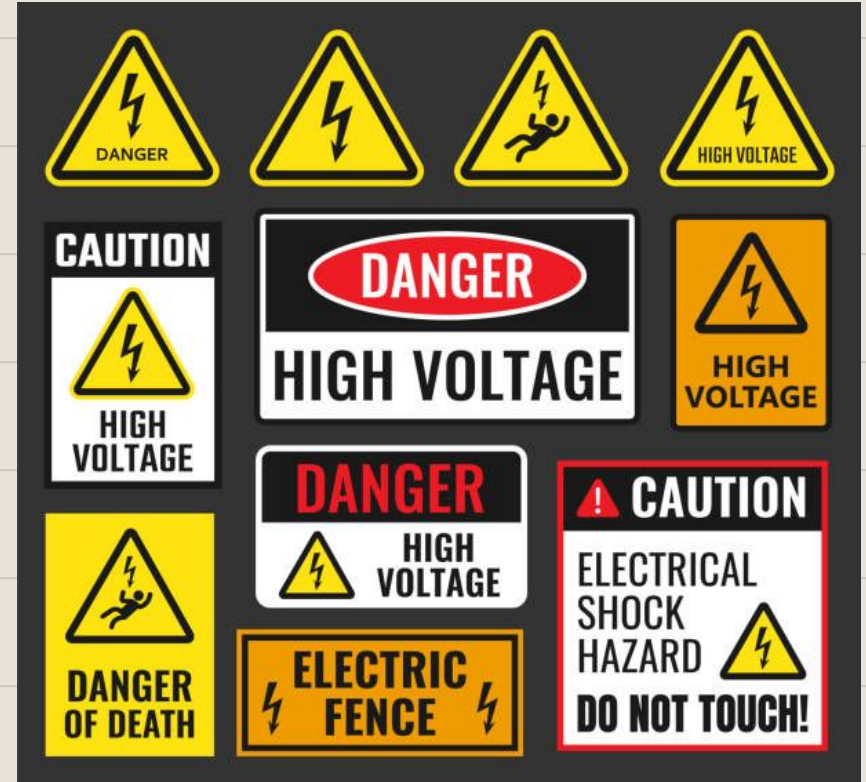

They are directly related.  $V=IR$

# Units (Metric System prefixes, aka powers of 10)

## Micro ( $\mu$ )

= One millionth

**Factor:**  $10^{-6} = 0.000001$

**Say 20 microamps (20  $\mu$ A)**

Means 0.000020 amps.

## Milli (m)

= One thousandth

**Factor:**  $10^{-3} = 0.001$

**Say 450 millivolts (450 mV)**

Means 0.450 V

## Killo (k)

= One thousand

**Factor:**  $10^3 = 1,000$

**Say 10 kilo ohm**

Means 10,000 ohms

# Polarity



Generally we follow the convention:

**Current flows positive to negative.**

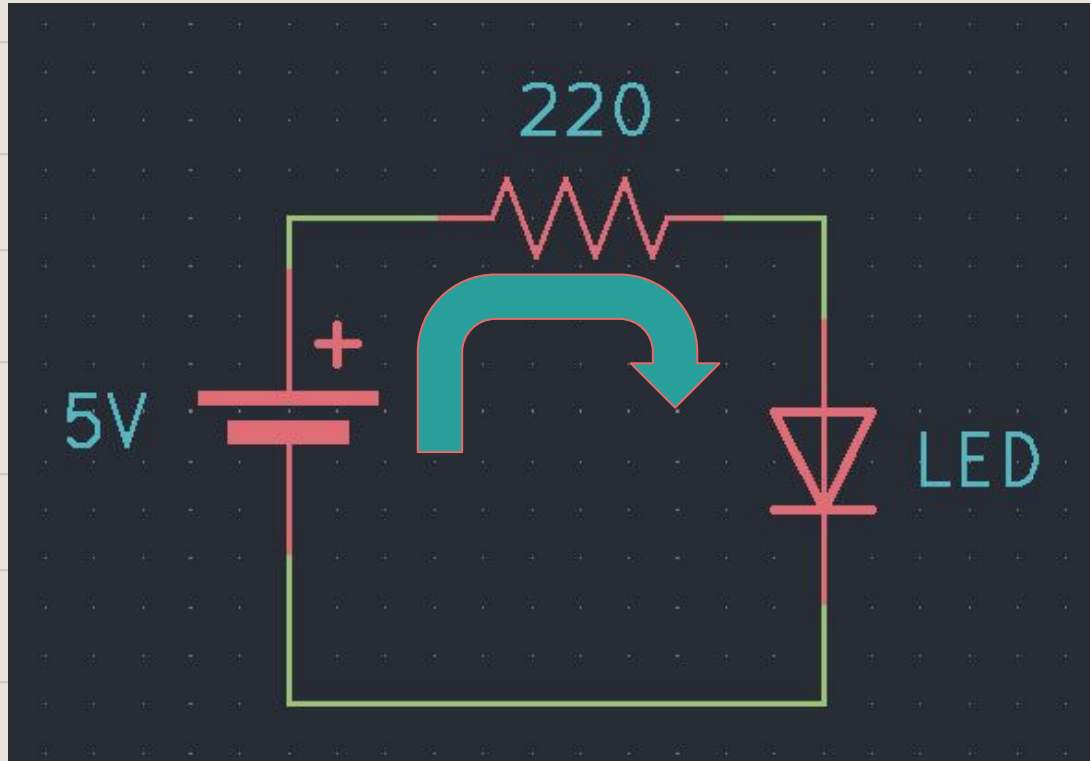

# Ohm's Law

$$V = I * R$$

How much current flows  
in this circuit?

Solve for I:

V=5, R= 220

I= ?

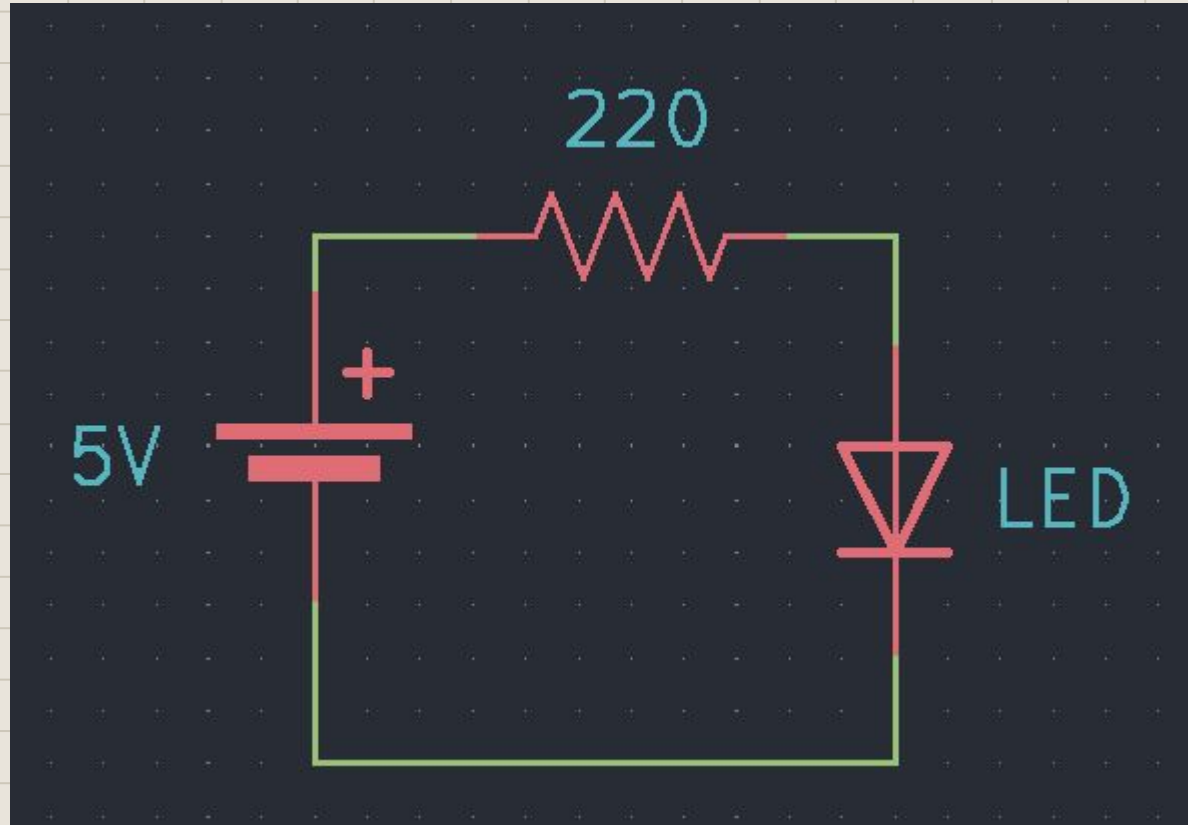

# Ohm's Law *(the only math you really need to know)*

$$V = I * R$$

Voltage = Current \*  
Resistance

## Variables:

V = Voltage, R = Resistance, I = Current.

$$I = V / R$$

## Power:

$$P = V * I$$

$$R = V / I$$

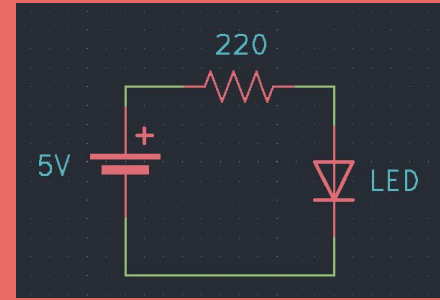

## Solve for I:

$$V = I * R$$
$$5 = I * 220$$
$$I = ?$$

# MultiMeter!

Voltage = 0-600V (!)

Amperage:  
0-200mA; 0-10A

Resistance /  
Continuity: 0-2M  
Ohms



# MultiMeter!

Let's measure some stuff:

- DC Voltage
- Resistance
- Continuity

Mind your **polarity!**

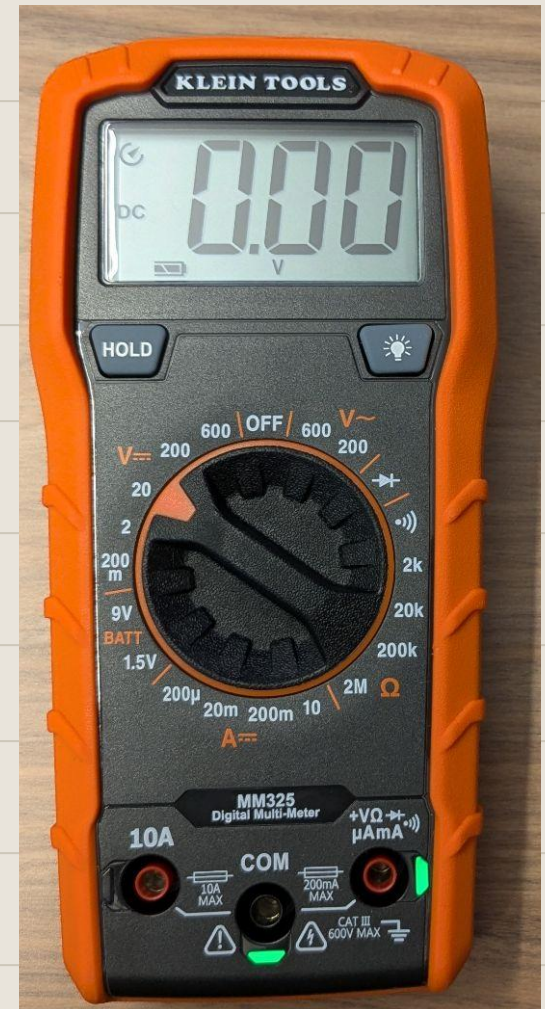

# DC Power Supply

Note 1

Probably the 2nd most useful electronics tool ever.





# Read your info plates

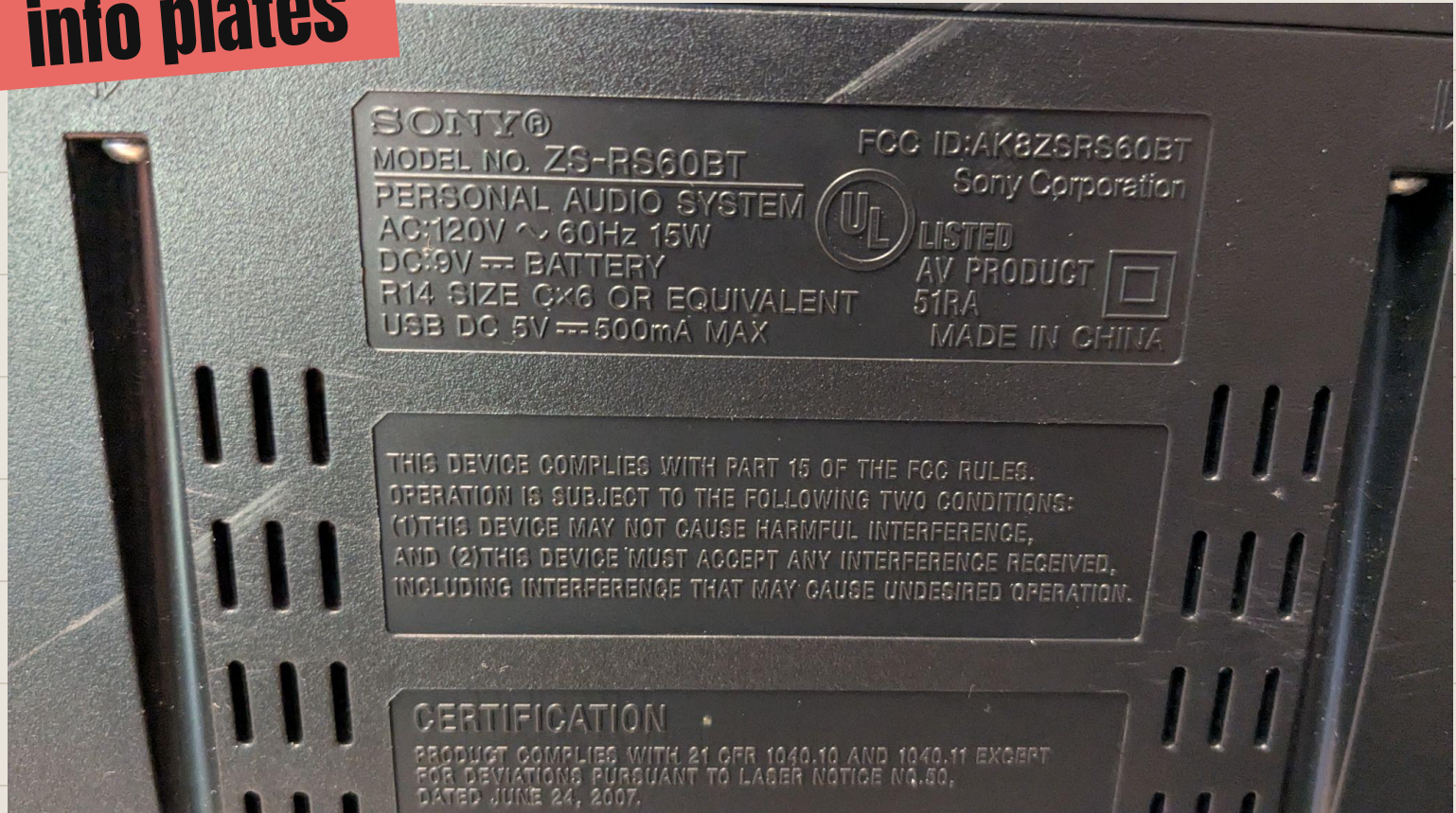

# Series vs. Parallel

Always portional.  
Based on system needs: duration or strength.

Always. Respect. Battery Datasheet.

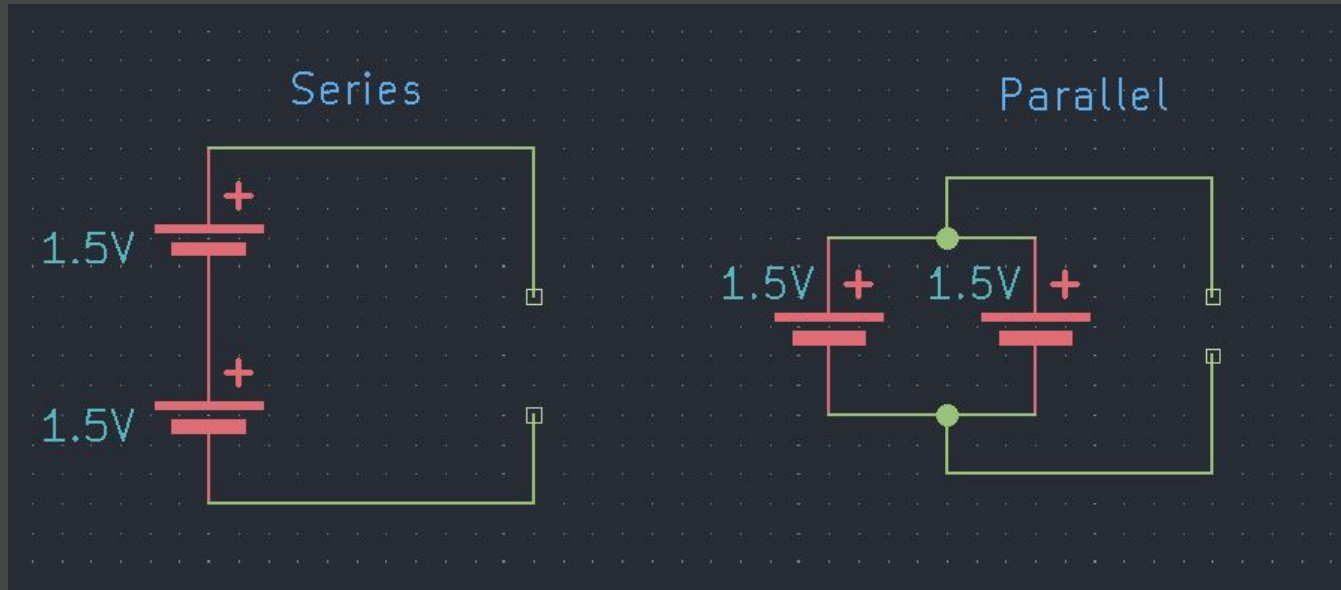

What do you do  
if battery starts  
a thermal  
runaway?

What is Li-ion?

# Series vs. Parallel

Battery Datasheet:

<https://www.dnkpowers.com/wp-content/uploads/2018/04/Samsung-INR18650-25R-Datasheet.pdf>

-SAMSUNG SDI Confidential Proprietary -



Spec. No.	INR18650-25R	Version No.	1.0	In-Young Jang
-----------	--------------	-------------	-----	---------------

## 1.0. Scope

This product specification has been prepared to specify the rechargeable lithium-ion cell ('cell') to be supplied to the customer by Samsung SDI Co., Ltd.

## 2.0. Description and model name

2.1 Description lithium-ion rechargeable cell

2.2 Model name INR**18650**-25R

## 3.0. Nominal specifications

Item	Specification
3.1 Nominal discharge capacity	<b>2,500mAh</b> Charge: 1.25A, 4.20V, CCCV 125mA cut-off, Discharge: 0.2C, 2.5V discharge cut-off
3.2 Nominal voltage	<b>3.6V</b>
3.3 Standard charge	CCCV, 1.25A, <b>4.20</b> ± 0.05 V, 125mA cut-off
3.4 Rapid charge	CCCV, 4A, <b>4.20</b> ± 0.05 V, 100mA cut-off
3.6 Charging time	Standard charge : 180min / 125mA cut-off Rapid charge: 60min (at 25°C) / 100mA cut-off
3.7 Max. continuous discharge (Continuous)	20A(at 25°C), 60% at 250 cycle
3.8 Discharge cut-off voltage End of discharge	2.5V

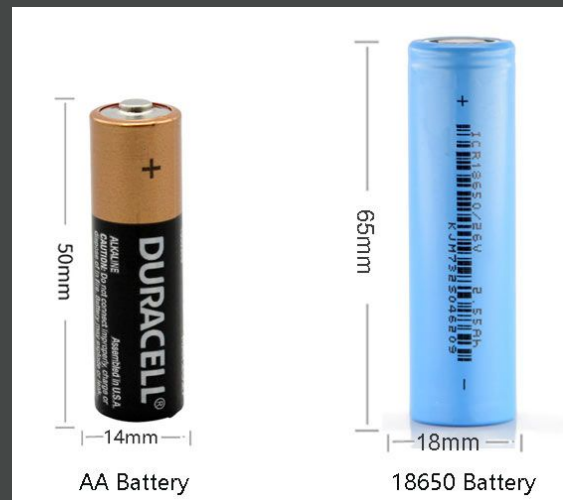

# Series vs. Parallel

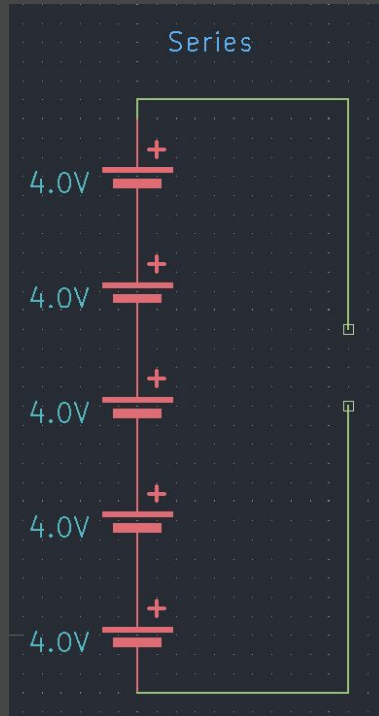

How many 18650 cells make a power tool battery pack?

What configuration would make the battery pack last longer?



# Series vs. Parallel

How many 18650 cells make a power tool battery pack?

What configuration would make the battery pack last longer?

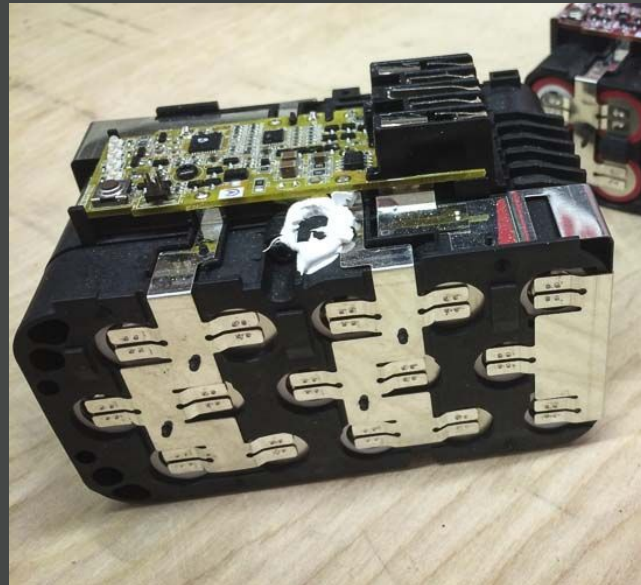
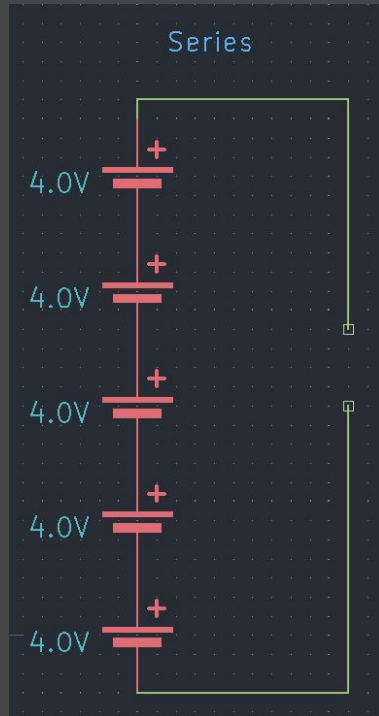

Account Detail

123 MAIN ST

Supplier Agreement ID: 0000000000

Meter Reading Usage Information

Meter Number	F00000000
Present 10/29/2023 Act	76,026.3670
Prior 09/28/2023 Act	75,468.7020
Difference	557.6650
Your Meter Multiplier	1
Total kWh Used	557.6650



Current Bill Details

DLC Rate	RS-Residential Service		
Price to Compare	\$0.1145 / kWh		
<b>DLC Charges</b>			<b>\$63.15</b>
Customer Charge		\$12.50	
Distribution	557.6650 kWh@ \$0.087833	\$48.98	
DSIC Surcharge	2.86%	\$1.76	
Pennsylvania Tax Adjustment		-\$0.09	
<b>Supply Charges - ABC ENERGY</b>			<b>\$91.40</b>
Generation-Trans	557.6650 kWh@ \$0.163900	\$91.40	



Your Electric Bill

# Kill-a-watt

**Audit your  
energy use.**

costs:

Distribution

\$0.088 /kWH

Generation

+ \$0.164 / kWH

Total charges

\$0.252 / KWH

# French Fries

How much electricity does a plate of fries cost to cook?

Go ahead, guess.



# French Fries

**How much electricity  
does plate of fries cost to  
cook?**

**Go ahead, guess.**



AIR FRYER

Model/Modèle #: MCAF56DB

120V~60Hz 1700W

DO NOT IMMERSE INTO WATER/  
NE PAS IMMÉRER  
HOUSEHOLD USE ONLY/  
USAGE DOMESTIQUE SEULEMENT  
MADE IN CHINA/FABRIQUE EN CHINE



Intertek  
4007446

CONFORMS TO/  
CONFORME À LA NORME  
UL STD. 1026  
CERTIFIED TO/ CERTIFIÉ  
CSA STD. C22.2 NO.64

electric cost            \$0.252 / kWh  
Cook time:                15min

$$\$0.252 \times 0.25 \times 1.7 =$$











# Wire Gauge (Current Capacity)

“

Why solid core vs stranded core?

Some Common sizes for residential wiring.

	Wire Gauge	Current Carrying Capacity
	 14 AWG	15 Amps
	 12 AWG	20 Amps
	 10 AWG	30 Amps
	 8 AWG	50 Amps



# Wires in your house!



# Wires in your house!

## SINGLE-PHASE CENTER-TAPPED SERVICE: 120V & 240V

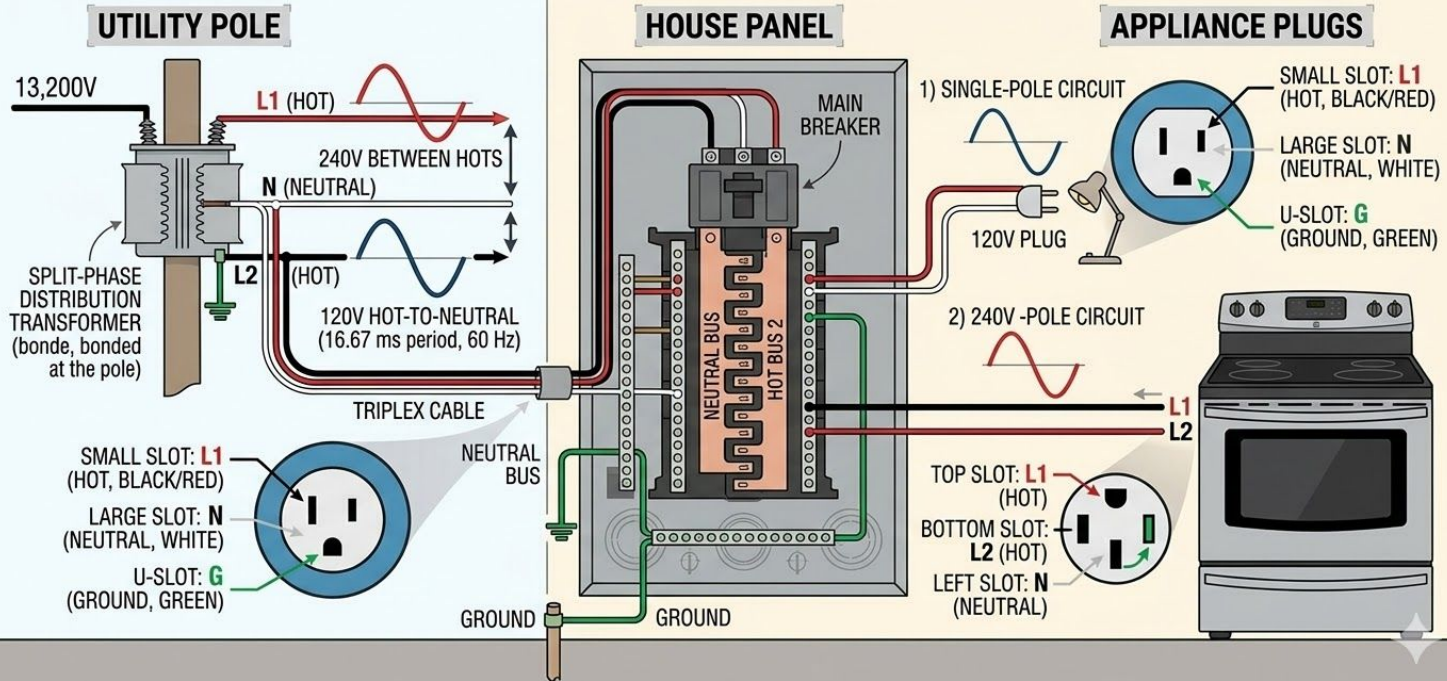

# Wires in your house! (simplified)

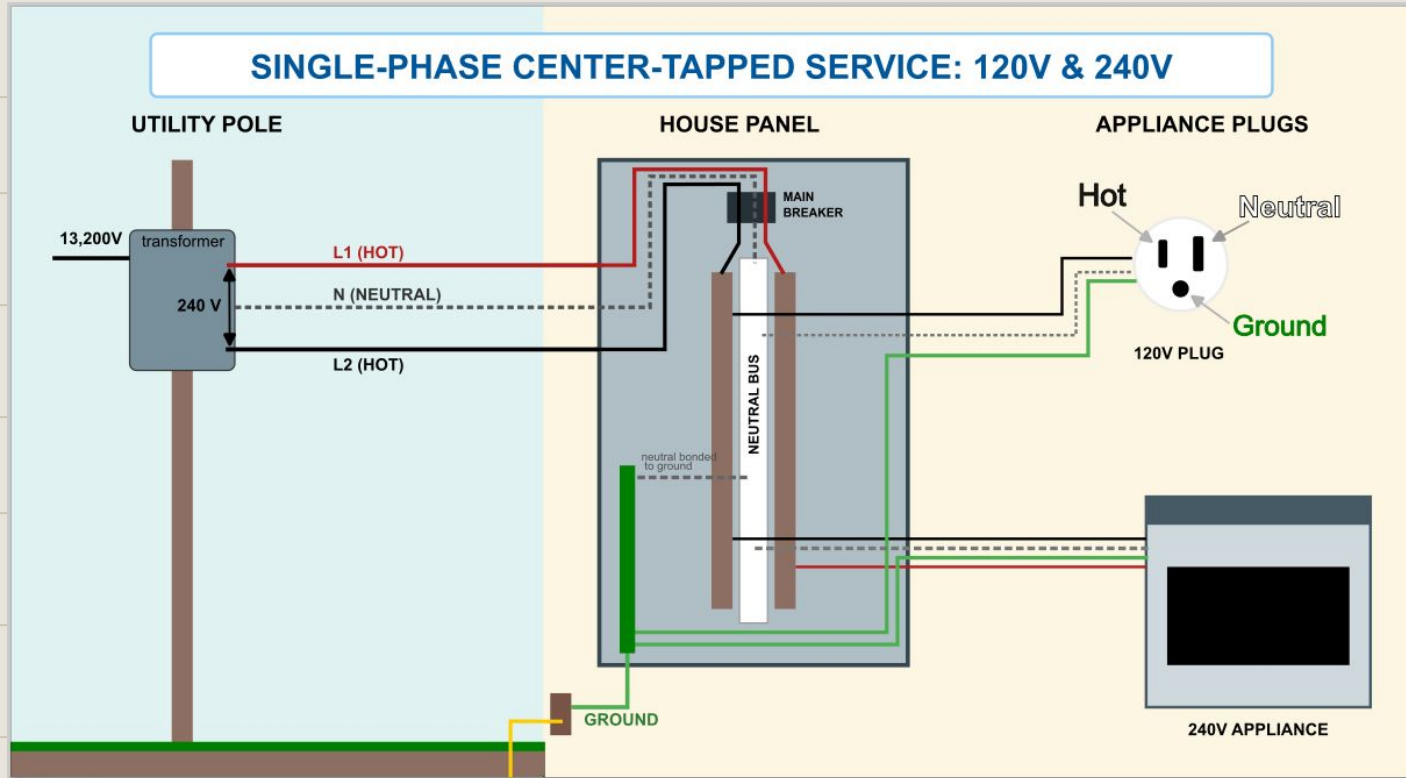

# Wires in your house!

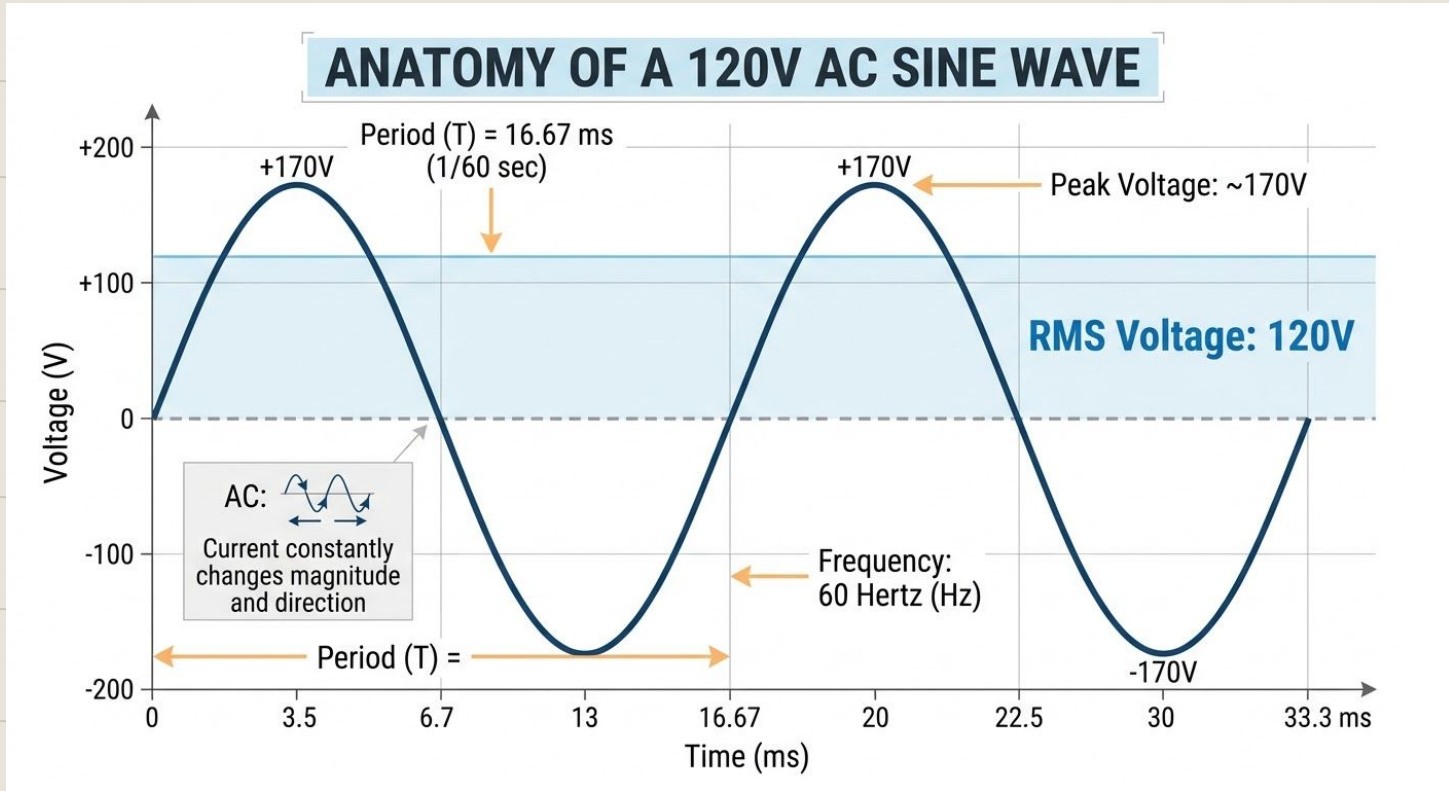

# Activity #1

Cosplay as an electrician.

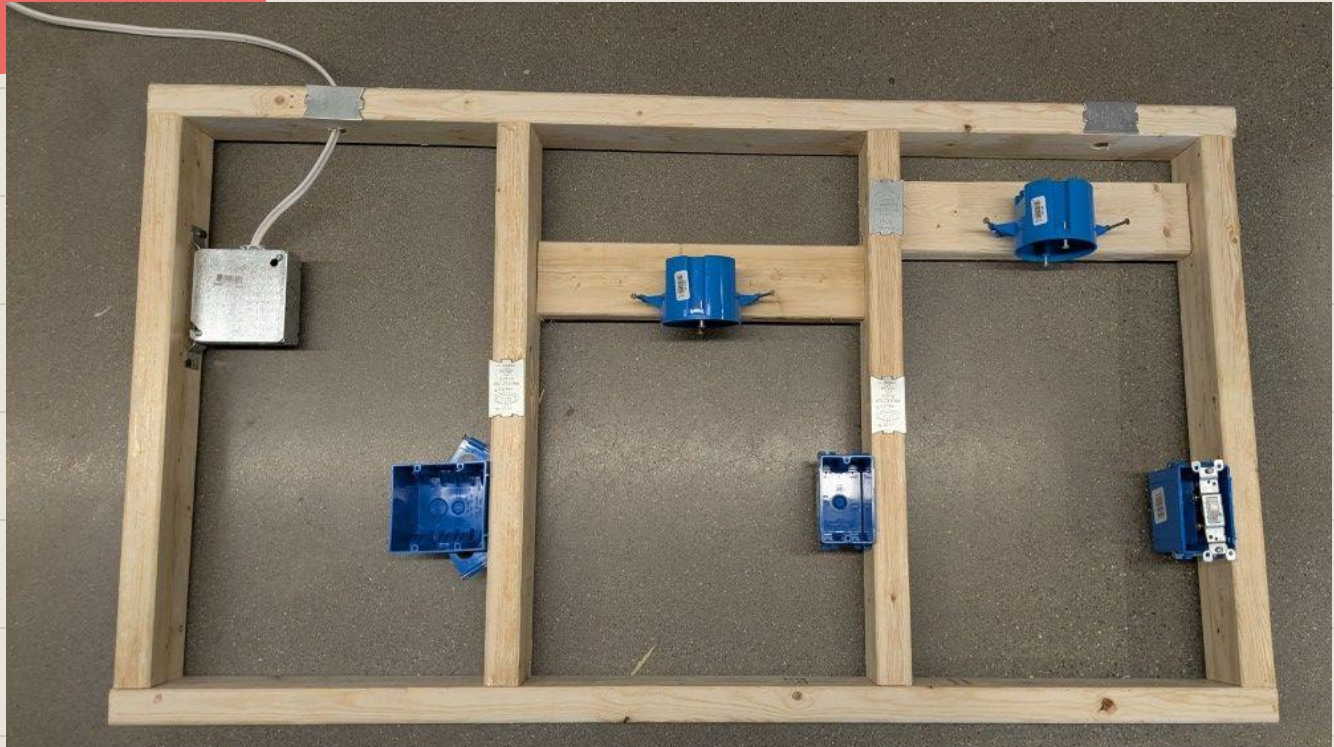

# Activity #1

## Goals:

- Familiarize with tools and parts:
- Translate a diagram to a circuit.

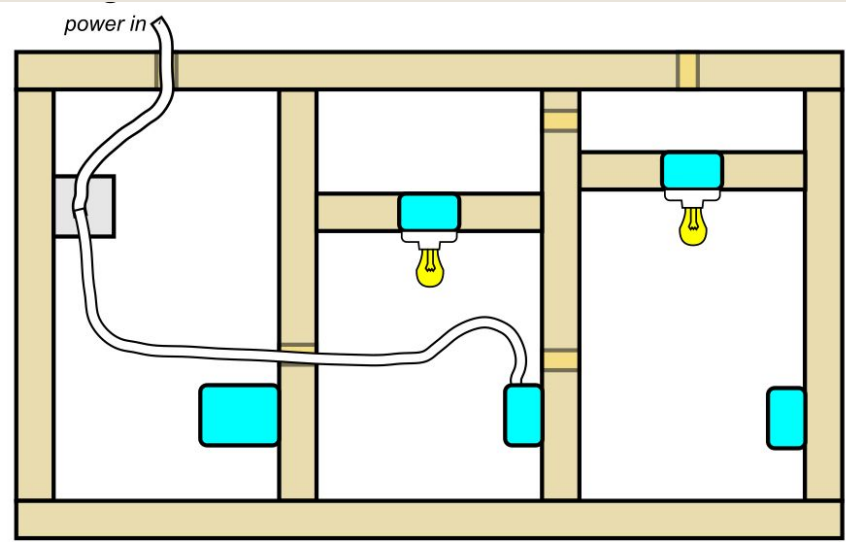
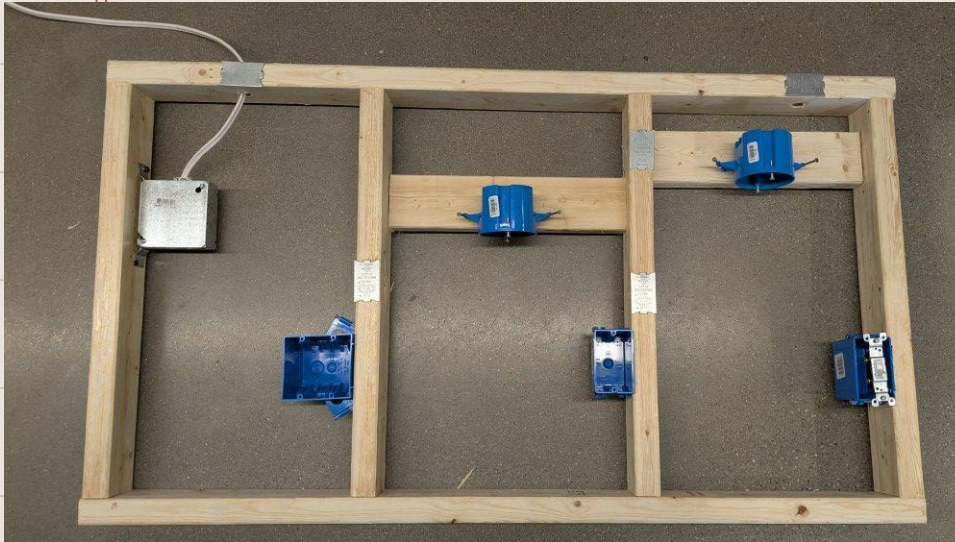

# Activity #1

Tools and PPE:

- a) wire strippers, screw driver, drill, utility knife
- b) safety glasses

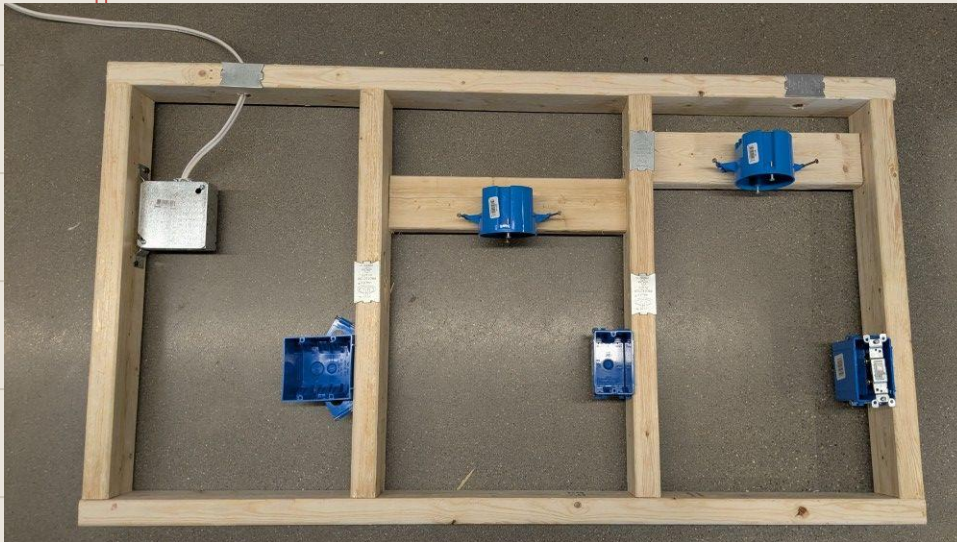

# Wire from a diagram.

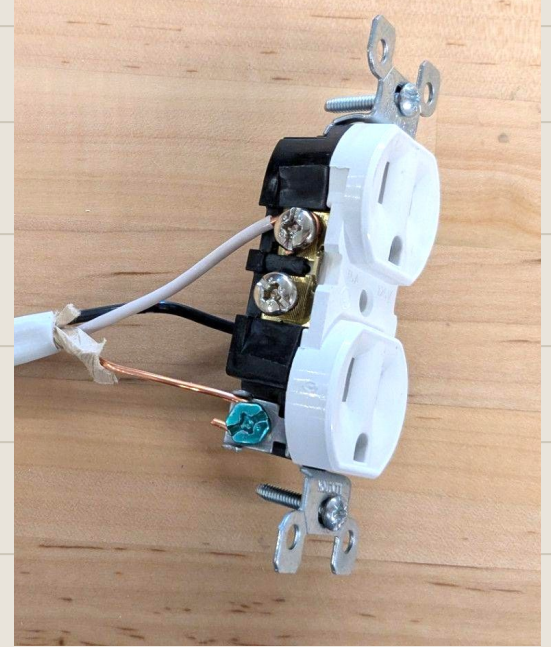
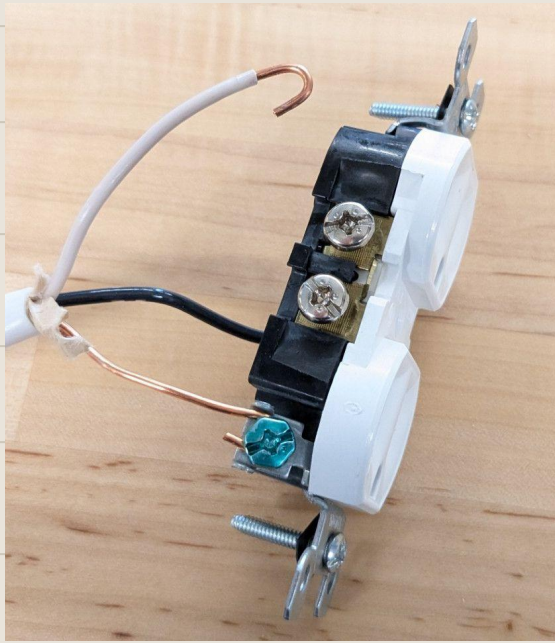
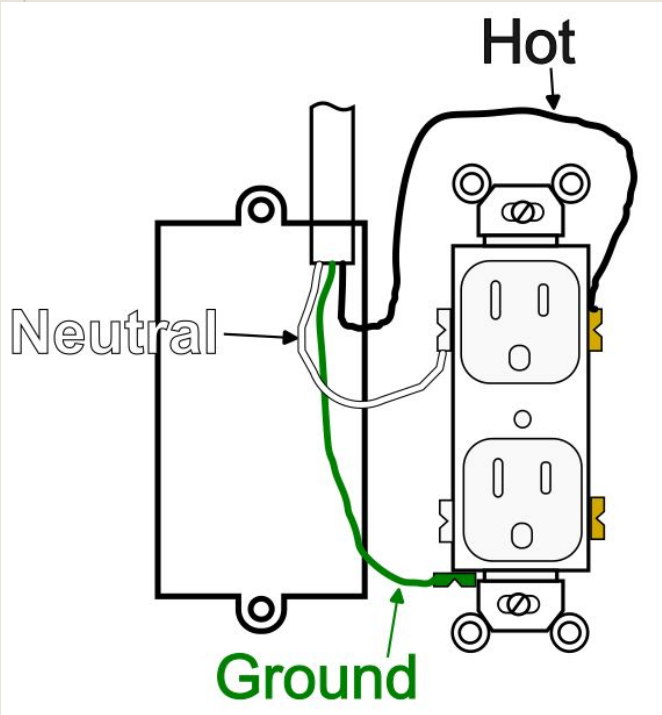

**To the lab!**



# Activity #2

Wire an “e-bike”.

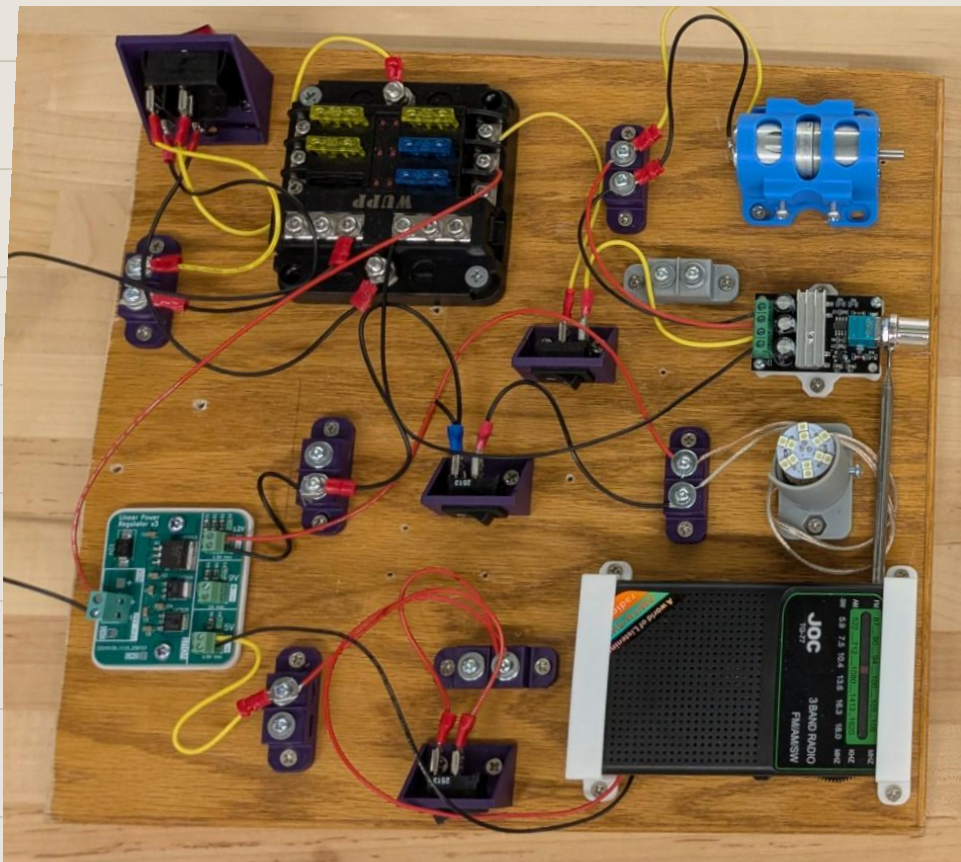

## Activity #2

Wire an “e-bike”  
from a diagram.

Goals:

- Use tools and parts:
- Translate a diagram to a circuit.

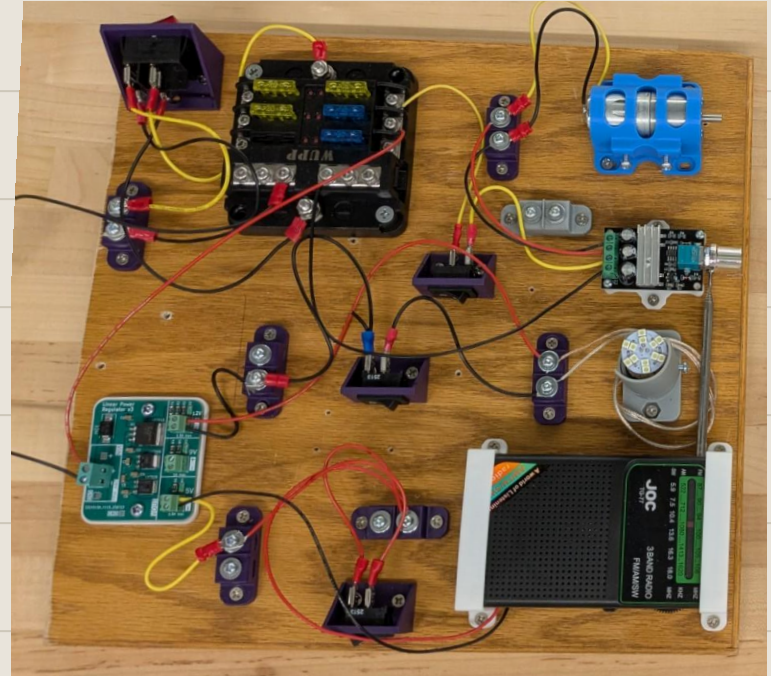

# Wire this diagram!

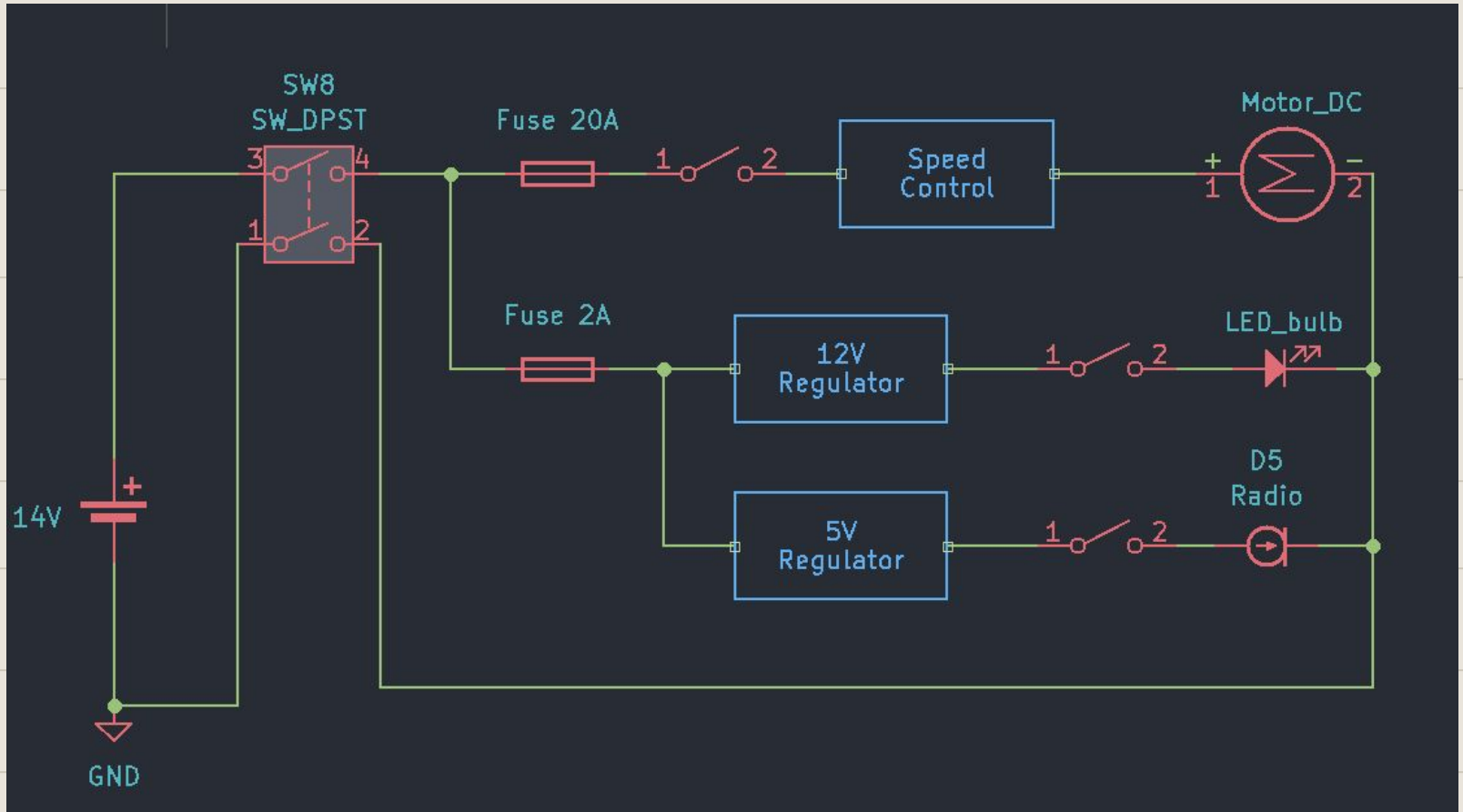

# Wire this schematic (same thing)!

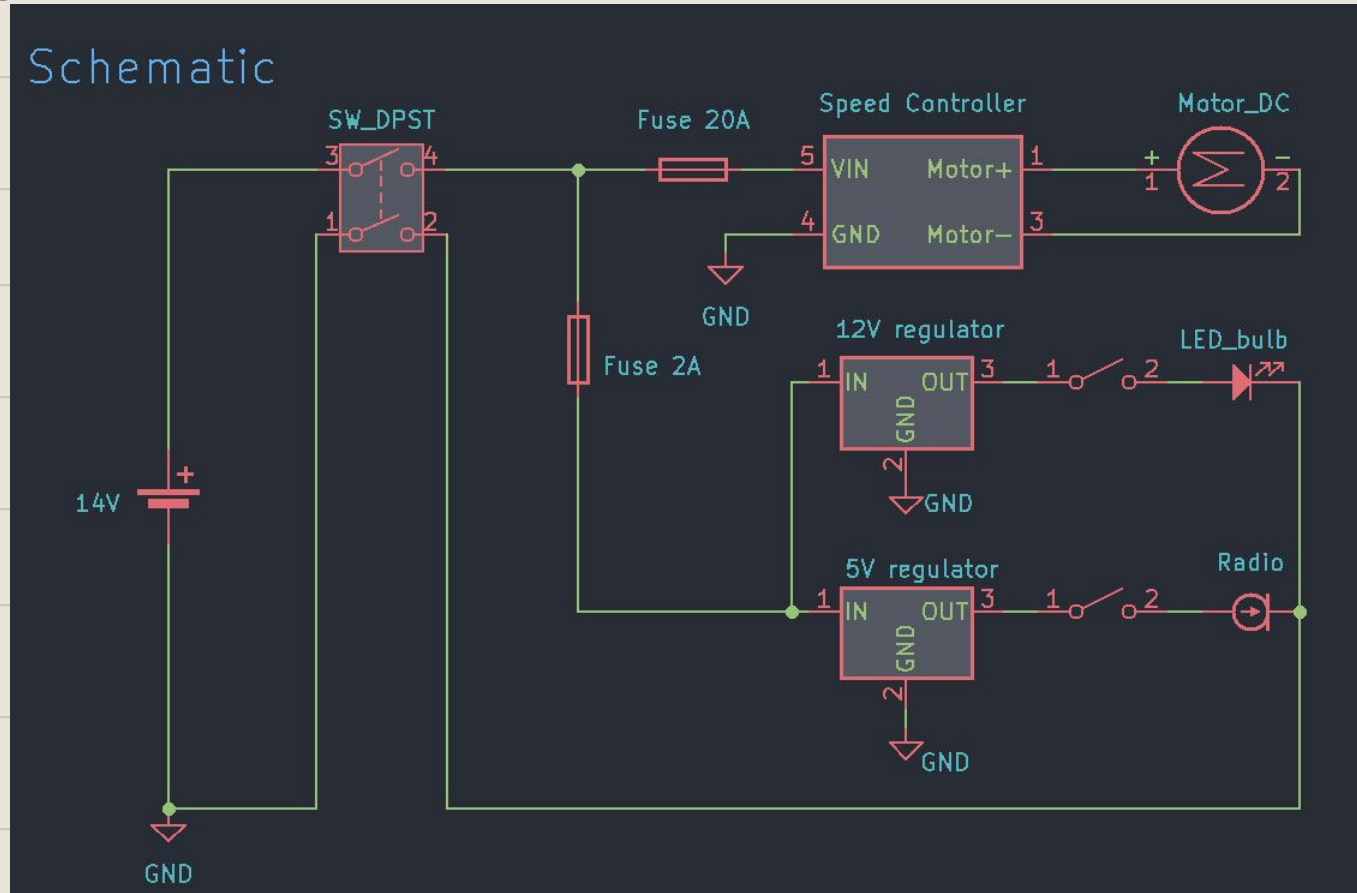

# Wire Termination ( a *few* connector types)

## 1. Crimp Connector

Module Connectors

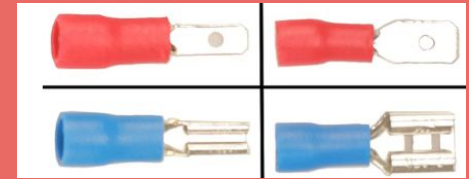

## 2. Ferrule

Use Stranded wire

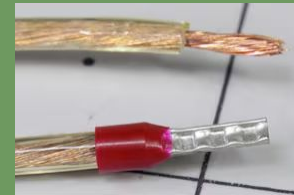

## 3. Barrier Strips, Screw Terminals

Wire to board (PCB) connector



# Crimp!

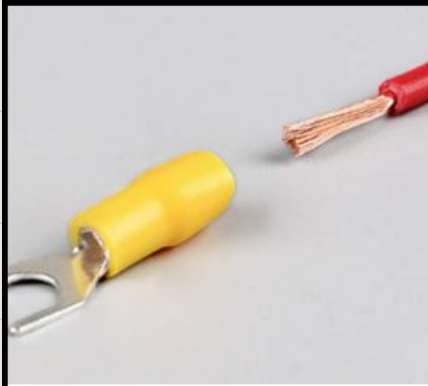

1. strip the wire jacket.



2. put the connector into a suitable jaw.

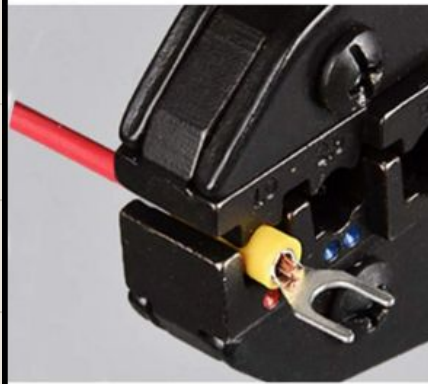

3. inset the wire into the connector.

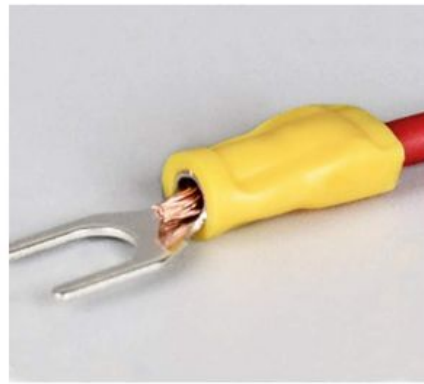

4. crimp the connector to hold the wire tightly.